



Bluetooth Module Datasheet

Model: TS3008-C

Version: V1.1

2019-07-05

Tinysine Electronics.

Tel: +86-551-65365921 Ext 801

E-mail: customerservice@tinyosshop.com

Web: www.tinyosshop.com

Hefei, Anhui, China

List of Contents

1 Introduction	3
2 Key Features	3
3 Applications	4
4 Block Diagram	4
5 General specifications	4
6 Module Package Information	5
6.1 Pinout Diagram and package dimensions	5
6.2 Module Pin descriptions	6
7 Electrical Characteristics	9
7.1 Absolute Maximum Ratings	9
7.2 Recommended Operating Conditions	9
8 Recommended reflow temperature profile	10

1 Introduction

Tinsine Electronics introduces the pioneer of the Bluetooth5.0 modules TS3008-C which is a high performance, cost effective, low power and compact solution. The Bluetooth module provides a complete 2.4GHz Bluetooth system based on the QCC3008 QFN chipset which is a singlechip radio and baseband IC for Bluetooth 2.4GHz systems,. This module is fully qualified single-chip dual mode Bluetooth@v5.0 system.

2 Key Features

Bluetooth Profiles

- Bluetooth v5.0 specification support
- Qualcomm® Bluetooth® Low Energy secure connection
- A2DP v1.3.1
- AVRCP v1.6
- HFP v1.7
- HSP v1.2
- SPP v1.2
- DID v1.3
- HOGP v1.0
- PXP v1.0.1
- FMP v1.0
- BAS v1.0
- QTIL's proximity pairing and QTIL's proximity connection

Music Enhancements

- aptX, aptX Low Latency, SBC, and AAC audio codecs
- Qualcomm TrueWireless™ Stereo (TWS), which allows two devices to be configured as a stereo pair
- Configurable Signal Detection to trigger events
- 1 bank of up to 10-stage Speaker Parametric EQ
- 6 banks of up to 5-stage User Parametric EQ for music enhancement
- Qualcomm® meloD™ Expansion audio processing: 3D stereowidening
- Comander to compress or expand the dynamic range of the audio
- Post Mastering to improve DAC fidelity
- Dual I²S outputs with crossover

Additional Functionality

- Support for multi-language programmable audio prompts
- Multipoint support for A2DP connection to 2 A2DP sources for music playback
- Talk-time extension, which automatically reduces processor functions to extend use when a low battery condition is detected
- Slim module with 13.5mm x 21mm x 2.0mm

3 Applications

- Stereo Headsets
- Wired Stereo headsets and headphones
- Portable Bluetooth Stereo speakers

4 Block Diagram

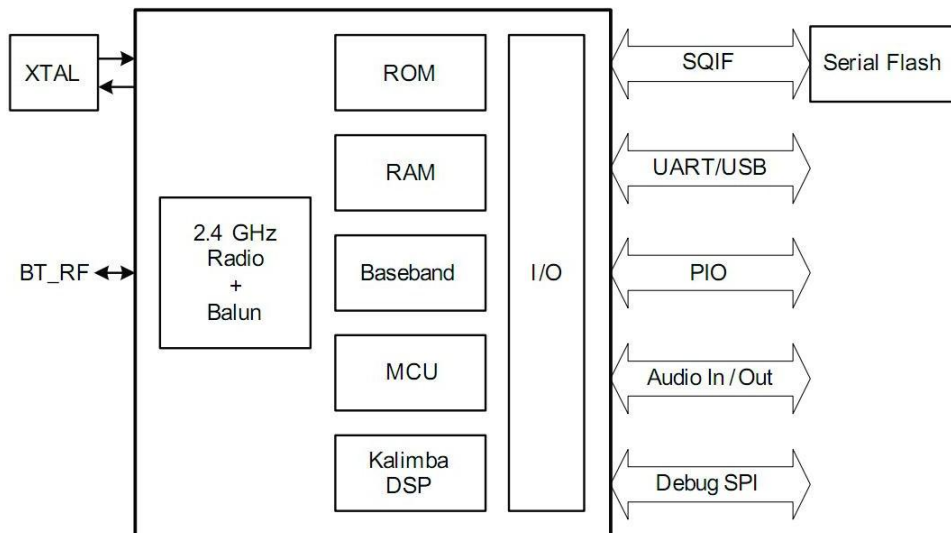

5 General specifications

Model Name	TS3008-C
Product Description	Bluetooth 5.0 Class2 Module
Bluetooth Standard	Bluetooth 5.0
Chipset	QCC3008 QFN
Dimension	13.5mm x 21mm x 2.0mm
Operating Conditions	
Voltage	2.8~4.2V
Temperature	-10~+70°C
Storage Temperature	-40~+85°C
Electrical Specifications	
Frequency Range	2402~2480MHz
Maximum RF Transmit Power	9dBm
$\pi/4$ DQPSK Receive Sensitivity	-92dBm
8DPSK Receive Sensitivity	-82dBm

6 Module Package Information

6.1 Pinout Diagram and package dimensions

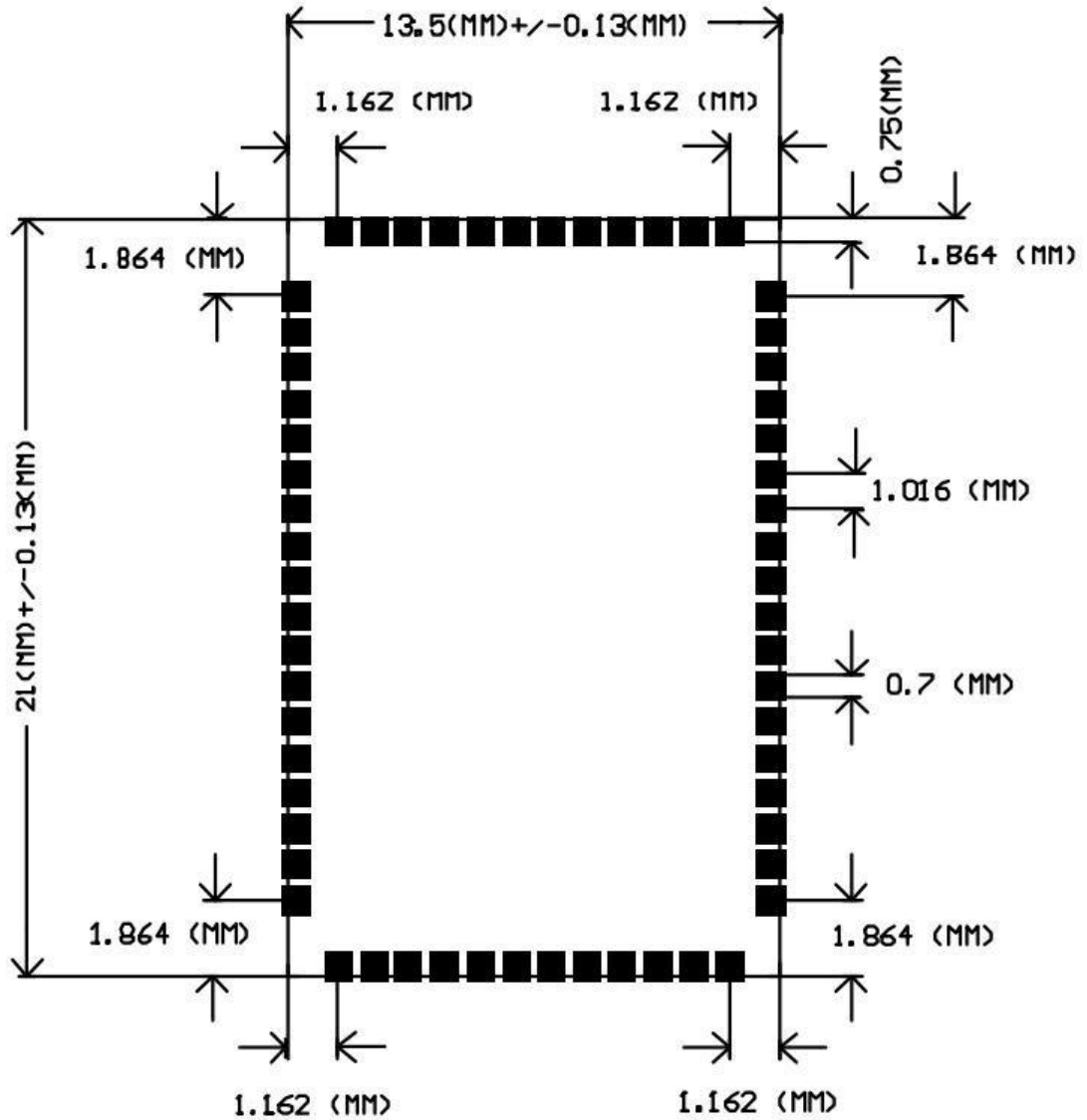

Unit: MM

Recommended PCB layout footprint

6.2 Module Pin descriptions

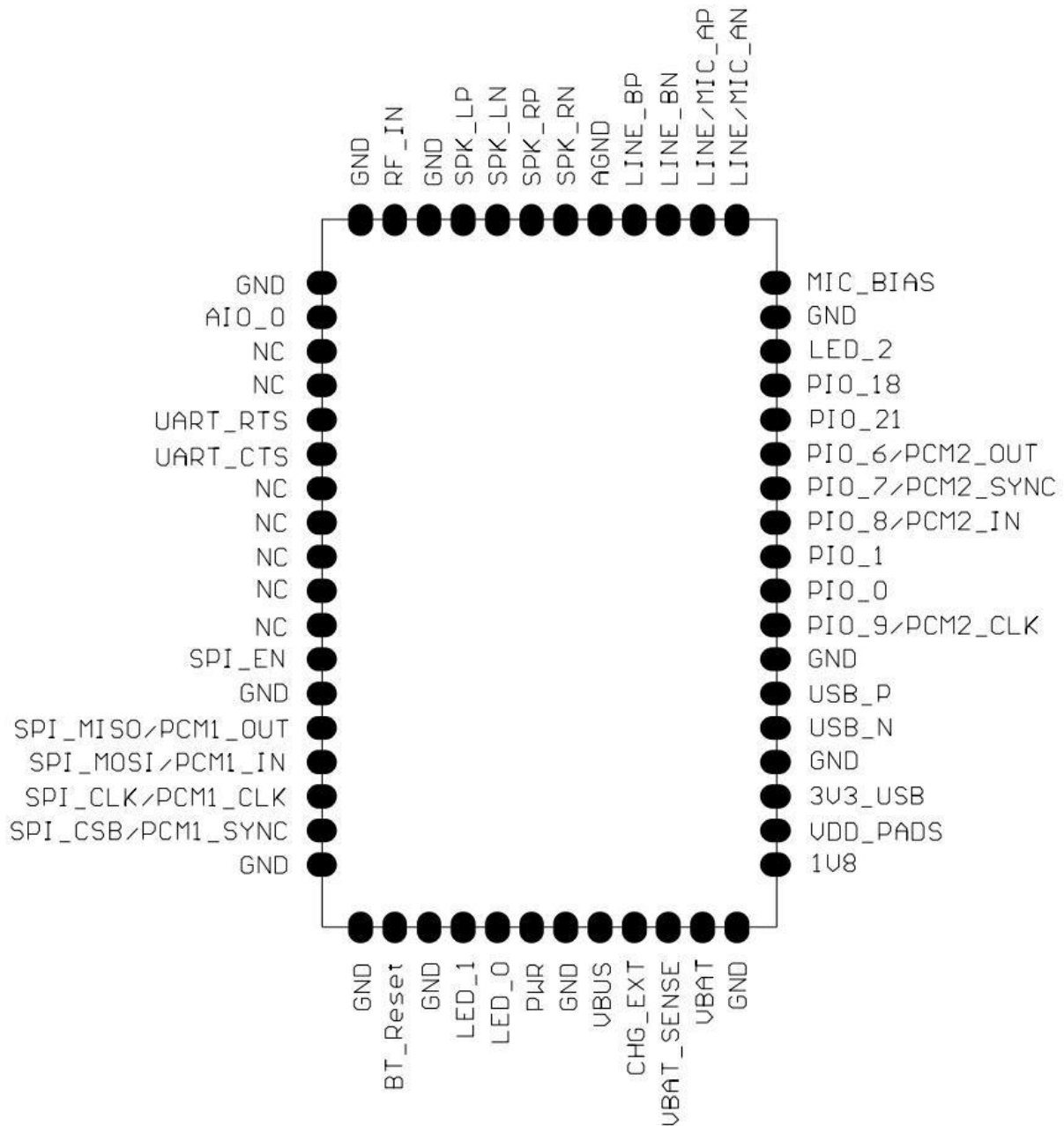

Pin#	Pin Name	Pin Type	Description
1	GND	Ground	Ground
2	AIO_0	Analogue input/output	Analogue programmable input/ output line 0.
3	NC	NC	NC
4	NC	NC	NC
5	UART_RTS/PIO_16	Bidirectional with strong pull-up	UART request to send, active low Alternative function: ■ PIO_16 Programmable input/output line 16.

6	UART_CTS/PIO_17	Bidirectional with strong pull-down	UART clear to send active low Alternative function: ■ PIO_17 Programmable input/output line 17.
7	NC	NC	NC
8	NC	NC	NC
9	NC	NC	NC
10	NC	NC	NC
11	NC	NC	NC
12	SPI_PCM	Input with weak pull-down	SPI/I2S# select input ■ 0=I2S/PIO interface ■ 1=SPI
13	GND	Ground	Ground
14	SPI_MISO	Bidirectional with weak pull-down	SPI data output Alternative function: ■ PIO_3: Programmable input/output line 3. ■ I2S1_SD_OUT: I2S1 synchronous data output
15	SPI_MOSI	Bidirectional with weak pull-down	SPI data input Alternative function: ■ PIO_2: Programmable input/output line ■ SPDIF_IN: SPDIF input ■ I2S1_SD_IN: I2S1 synchronous data input
16	SPI_CLK	Bidirectional with weak pull-down	SPI clock Alternative function: ■ PIO_5: Programmable input/output line ■ I2S1_CLK: I2S1 synchronous data clock
17	SPI_CSB	Bidirectional with weak pull-down	Chip select for SPI, active low Alternative function: ■ PIO_4: Programmable input/output line 4. ■ I2S1_WS: I2S1 word select
18	GND	Ground	Ground
19	GND	Ground	Ground
20	BT_Reset	Input with strong pull-up	Reset if low. Pull low for minimum 5 ms to cause a reset
21	GND	Ground	Ground
22	LED_1	Bidirectional	Open-drain output
23	LED_0	Bidirectional	Open-drain output
24	PWR	CMOS Input	Regulator enable and multifunction button. A high input (tolerant to VBAT voltages) enables the on-chip regulators, which can then be latched on internally and the button used as a multifunction input.
25	GND	Ground	Ground
26	VBUS	Charge input	Charge input. Typically connected charger
27	CHG_EXT	External battery charger control	External battery charger transistor base control when using external charger boost. Otherwise leave unconnected.
28	VBAT_SENSE	CMOS Input	Battery charger sense input.
29	VBAT	Power Input	Positive supply for BT Module, or battery positive terminal

30	GND	Ground	Ground
31	1V8	Power output	Auxiliary regulator output (1.8V out)
32	VDD_PADS	Power output	3.3V Positive supply output
33	3V3_USB	Power output	3.3V bypass linear regulator output
34	GND	Ground	Ground
35	USB_N	Bi-directional	USB data minus
36	USB_P	Bi-directional	USB data plus with selectable internal 1.5kΩ pull-up resistor
37	GND	Ground	Ground
38	PIO_9	Bidirectional with strong pull-down	Programmable input/output line 9. Alternative function: ■ UART_CTS: UART clear to send, active low ■ I2S2_SD_IN: I ² S2 synchronous data input
39	PIO_0	Bidirectional with strong pull-up	Programmable input/output line 0. Alternative function: ■ UART_RX: UART data input
40	PIO_1	Bidirectional with strong pull-up	Programmable input/output line 1. Alternative function: ■ UART_TX: UART data output
41	PIO_8	Bidirectional with strong pull-up	Programmable input/output line 8. Alternative function: ■ UART_RTS: UART request to send, active low ■ I2S2_SD_IN: I ² S2 synchronous data input
42	PIO_7	Bidirectional with strong pull-down	Programmable input/output line 7. ■ I2S2_WS: I2S2 word select
43	PIO_6	Bidirectional with strong pull-down	Programmable input/output line 6. ■ I2S2_SD_OUT: I2S2 synchronous data output
44	PIO_21	Bidirectional with weak pull-down	Programmable input/output line 21.
45	PIO_18	Bidirectional with weak pull-down	Programmable input/output line 18.
46	LED_2	Bidirectional	Open-drain output
47	GND	Ground	Ground
48	MIC_BIAS	Analogue	Microphone bias
49	LINE/MIC_AN	Analogue in	Microphone input negative, channel A
50	LINE/MIC_AP	Analogue in	Microphone input positive, channel A
51	LINE_BN	Analogue in	Line-in negative, channel B
52	LINE_BP	Analogue in	Line-in positive, channel B
53	GND	Ground	Ground
54	SPK_RN	Analogue OUT	Speaker output negative, right
55	SPK_RP	Analogue OUT	Speaker output positive, right
56	SPK_LN	Analogue OUT	Speaker output negative, left
57	SPK_LP	Analogue OUT	Speaker output positive, left
58	GND	Ground	Ground
59	RF_IN	RF	Bluetooth 50Ω transmitter output/receive input
60	GND	Ground	Ground

7 Electrical Characteristics

7.1 Absolute Maximum Ratings

Rating	Minimum	Maximum
Storage temperature	-40°C	+85°C

7.2 Recommended Operating Conditions

Operating Condition	Minimum	Maximum
Operating temperature range	-10°C	+70°C
Supply voltage: VBAT	+2.8V	+4.2V

8 Recommended reflow temperature profile

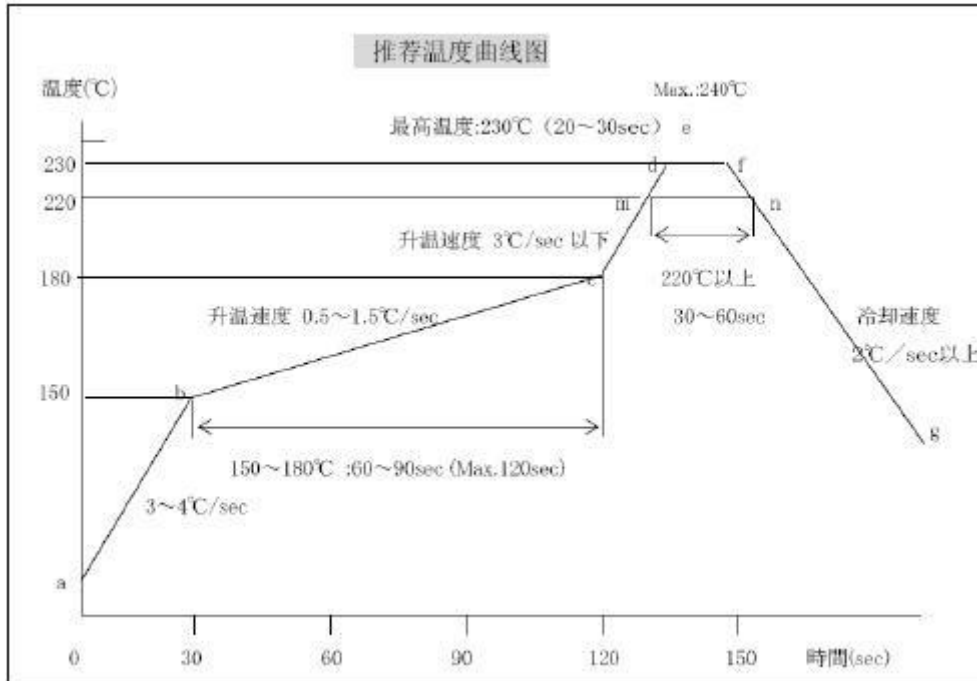



CAUTION
This bag contains
MOISTURE-SENSITIVE DEVICES

LEVEL

3

If Blank, see adjacent bar code label

1. Calculated shelf life in sealed bag:12 months at < 40 °C and < 90% relative humidity (RH)
2. Peak package body temperature: _____ 260 _____ °C
If Blank, see adjacent bar code label
3. After bag is opened, devices that will be subjected to reflow solder or other high temperature process must
 - a) Mounted within: _____ 168 _____ hours of factory
If Blank, see adjacent bar code label
 conditions ≤ 30 °C / 60 %
 b) stored at < 10%RH
4. Devices require bake, before mounting, if :
 - a) Humidity Indicator Card is > 10 %when read at 23 ± 5 °C
 - b) 3a or 3b not met.
5. If baking is required, devices may be baked for 48 hours at 125 ± 5 °C
 Note: If device containers cannot be subjected to high temperature or shorter bake times are desired,
 reference IPC /JEDEC J-STQ-033 for bake procedure

Bag Seal Date: _____
 If Blank, see adjacent bar code label

Note: Level and body temperature defined by IPC /JEDEC J-STQ-020

The module Must go through 125°C baking for at least 9 hours before SMT AND IR reflow process!

若拆封后未立即上线，我们建议让模块下次上线前务必以 125°C烘烤 9 小时以上！

Record of Changes

Data	Revision	Description
2018-01-30	V1.0	Original publication of this document.
2019-07-05	V1.1	Fix PIN definition.

IMPORTANT NOTICE

Tinysine Technologies Co.,Ltd reserve the right to make changes to their products or to discontinue any product or service without notice, and advise customers to obtain the latest version of relevant information to verify, before placing orders, that information being relied on is current. All products are sold subject to the Tinysine terms and conditions of sale supplied at the time of order acknowledgement, including those pertaining to warranty, patent infringement, and limitation of liability.

Tinysine warrants performance of its products to specifications applicable at the time of sale in accordance with Tinysine's standard warranty. Testing and other quality control techniques are utilized to the extent SJR deems necessary to support this warranty. Specific testing of all parameters of each device is not necessarily performed, except those mandated by government requirements.

In order to minimize risks associated with customer applications, adequate design and operating safeguards must be used by the customer to minimize inherent or procedural hazards. Tinysine products are not authorized for use as critical components in life support devices or systems without the express written approval of an officer of the company. Life support devices or systems are devices or systems that are intended for surgical implant into the body, or support or sustain life, and whose failure to perform when properly used in accordance with instructions for use provided, can be reasonably expected to result in a significant injury to the user. A critical component is any component of a life support device or system whose failure to perform can be reasonably expected to cause the failure of the life support device or system, or to affect its safety or effectiveness.

Tinysine assumes no liability for applications assistance or customer product design. Tinysine does not warrant or represent that any license, either express or implied, is granted under any patent right, mask work right, or other intellectual property right of Tinysine covering or relating or any combination, machine, or process in which such products or services might be or are used.

Tel: +86-551-65365921 Ext 801

Fax : +86-551-65365931

Web: www.tinyosshop.com

E-mail: customerservice@tinyosshop.com